

PTC Thermistor : TPM-S Series

SMD PTC Thermistor for Temperature Sensing



■ Features

1. RoHS & Halogen-free compliant
2. Thermistor chip with lead-free tinned terminals
3. EIA size 0402,0603,0805
4. Fast and reliable response
5. Suitable for reflow soldering
6. Agency Recognition:
7. UL & cUL : File No. E138827
TUV : File No. R50133294



■ Recommended Applications

1. DC/DC converter
2. AC adapter
3. Inverter
4. Overheat protection for transistor and ICs
5. LED

■ Part Number Code

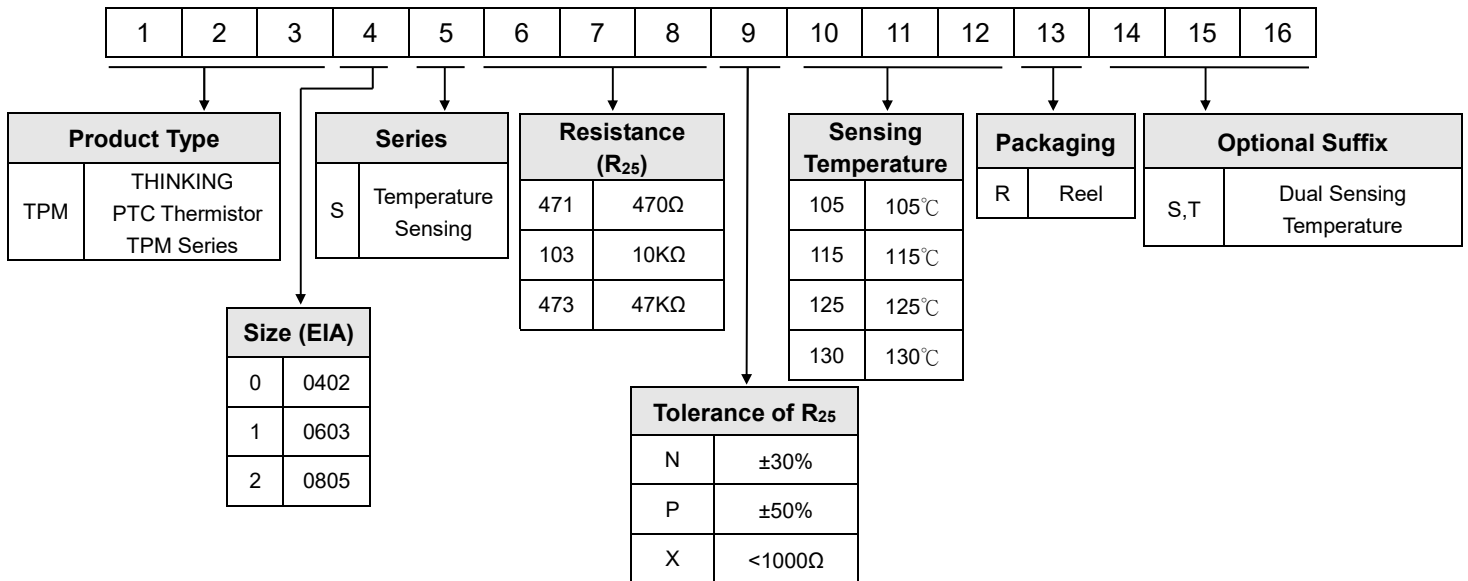

■ Structure and Dimensions

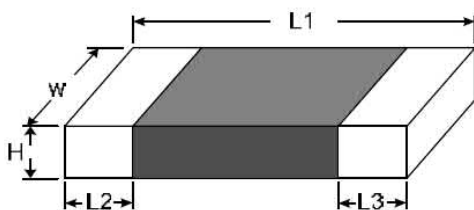

(Unit: mm)

Part No.	Size (EIA)	L1	W	H max.	L2 and L3
TPM0	0402	1.00±0.15	0.50±0.10	0.60	0.20±0.10
TPM1	0603	1.60±0.15	0.80±0.15	0.95	0.40±0.20
TPM2	0805	2.00±0.20	1.25±0.20	1.00	0.45±0.25
				1.45 (Only for TPM2S150N130R)	

PTC Thermistor : TPM-S Series

SMD PTC Thermistor for Temperature Sensing



Electrical Characteristics

0402 Series

Part No.	Zero Power Resistance at 25°C	Sensing Temperature 1 at 4.7 KΩ	Sensing Temperature 2 at 47 KΩ	Max. Voltage	Operating Temperature Range	Safety Approvals	
	R ₂₅	T _{s1}	T _{s2}	V _{max}	T _L ~T _U	UL/cUL	TUV
	(Ω)	(°C)	(°C)	(V _{DC})	(°C)		
TPM0S471P095R	470	95±5	--	32	-25 ~ +110		
TPM0S471P105R		105±5	--		-25 ~ +120	√	√
TPM0S471P115R		115±5	--		-25 ~ +130	√	√
TPM0S471P125R		125±5	--		-25 ~ +140	√	√
TPM0S471P115RT		115±5	130±7		-25 ~ +140	√	√
TPM0S541N115RT	540	115±5	135±7		-25 ~ +150	√	

Part No.	Zero Power Resistance at 25°C	Sensing Temperature 1 at 10 KΩ	Sensing Temperature 2 at 100 KΩ	Max. Voltage	Operating Temperature Range	Safety Approvals	
	R ₂₅	T _{s1}	T _{s2}	V _{max}	T _L ~T _U	UL/cUL	TUV
	(KΩ)	(°C)	(°C)	(V _{DC})	(°C)		
TPM0S102P085R	1	85±5	--	32	-40 ~ +100	√	
TPM0S102P125R		125±5	--		-40 ~ +140	√	
TPM0S102P065RS		65±5	80±5		-40 ~ +90	√	
TPM0S102P075RS		75±5	90±5		-40 ~ +100	√	
TPM0S102P085RS		85±5	100±5		-40 ~ +110	√	
TPM0S102P095RS		95±5	110±5		-40 ~ +120	√	
TPM0S102P105RS		105±5	120±5		-40 ~ +130	√	
TPM0S102P115RS		115±5	130±5		-40 ~ +140	√	
TPM0S102P125RS		125±5	140±5		-40 ~ +150	√	
TPM0S102P065RT		65±5	80±3		-40 ~ +90	√	
TPM0S102P075RT		75±5	90±3		-40 ~ +100	√	
TPM0S102P085RT		85±5	100±3		-40 ~ +110	√	
TPM0S102P095RT		95±5	110±3		-40 ~ +120	√	
TPM0S102P105RT		105±5	120±3		-40 ~ +130	√	
TPM0S102P115RT		115±5	130±3		-40 ~ +140	√	
TPM0S102P125RT		125±5	140±3		-40 ~ +150	√	

PTC Thermistor : TPM-S Series

SMD PTC Thermistor for Temperature Sensing



0402 Series

Part No.	Zero Power Resistance at 25°C	Sensing Temperature at 4.7MΩ	Max. Voltage	Operating Temperature Range	Safety Approvals	
	R ₂₅	T _s	V _{max}	T _L ~T _U	UL/cUL	TUV
	(KΩ)	(°C)	(V _{DC})	(°C)		
TPM0S103P080R	10	80±5	32	-25 ~ +95	√	
TPM0S103P095R		95±5		-25 ~ +110		
TPM0S103P100R		100±5		-25 ~ +115	√	
TPM0S103P110R		110±5		-25 ~ +125	√	
TPM0S103P120R		120±5		-25 ~ +135	√	
TPM0S103P130R		130±5		-25 ~ +145	√	
TPM0S473P130R	47	130±5		-25 ~ +145	√	

0603 Series

Part No.	Zero Power Resistance at 25°C	Sensing Temperature at 1KΩ	Max. Voltage	Operating Temperature Range	Safety Approvals	
	R ₂₅	T _{s1}	V _{max}	T _L ~T _U	UL/cUL	TUV
	(Ω)	(°C)	(V _{DC})	(°C)		
TPM1S101N115R	100	115±7	24	-25 ~ +130		
TPM1S101N130R		130±7		-25 ~ +145	√	√

Part No.	Zero Power Resistance at 25°C	Sensing Temperature at 2.2KΩ	Max. Voltage	Operating Temperature Range	Safety Approvals	
	R ₂₅	T _s	V _{max}	T _L ~T _U	UL/cUL	TUV
	(Ω)	(°C)	(V _{DC})	(°C)		
TPM1S221N090R	220	90±7	24	-25 ~ +105	√	
TPM1S221N105R		105±7		-25 ~ +120	√	

Part No.	Zero Power Resistance at 25°C	Sensing Temperature 1 at 4.7KΩ	Sensing Temperature 2 at 47KΩ	Max. Voltage	Operating Temperature Range	Safety Approvals	
	R ₂₅	T _{s1}	T _{s2}	V _{max}	T _L ~T _U	UL/cUL	TUV
	(Ω)	(°C)	(°C)	(V _{DC})	(°C)		
TPM1S471P065R	470	65±5	--	32	-25 ~ +80	√	√
TPM1S471P075R		75±5	--		-25 ~ +90	√	√
TPM1S471P080R		80±5	--		-25 ~ +95		
TPM1S471P085R		85±5	--		-25 ~ +100	√	√

PTC Thermistor : TPM-S Series

SMD PTC Thermistor for Temperature Sensing



0603 Series

Part No.	Zero Power Resistance at 25°C	Sensing Temperature 1 at 4.7 KΩ	Sensing Temperature 2 at 47 KΩ	Max. Voltage	Operating Temperature Range	Safety Approvals	
	R ₂₅	Ts1	Ts2	V _{max}	T _L ~T _U	UL/cUL	TUV
	(Ω)	(°C)	(°C)	(V _{DC})	(°C)		
TPM1S471P095R	470	95±5	--	32	-25 ~ +110	√	√
TPM1S471P100R		100±5	--		-25 ~ +115		
TPM1S471P105R		105±5	--		-25 ~ +120	√	√
TPM1S471P110R		110±5	--		-25 ~ +125		
TPM1S471P115R		115±5	--		-25 ~ +130	√	√
TPM1S471P125R		125±5	--		-25 ~ +140	√	√
TPM1S471P135R		135±5	--		-25 ~ +150	√	√
TPM1S471P065RT		65±5	80±7		-25 ~ +90	√	√
TPM1S471P075RT		75±5	90±7		-25 ~ +100	√	√
TPM1S471P085RT		85±5	100±7		-25 ~ +110	√	√
TPM1S471P095RT		95±5	110±7		-25 ~ +120	√	√
TPM1S471P105RT		105±5	120±7		-25 ~ +130	√	√
TPM1S471P115RT		115±5	130±7		-25 ~ +140	√	√
TPM1S471P125RT		125±5	140±7		-25 ~ +150	√	√
TPM1S471P130RT		130±5	145±7		-25 ~ +155		
TPM1S471P135RT		135±5	150±7		-25 ~ +160	√	√

Part No.	Zero Power Resistance at 25°C	Sensing Temperature at 4.7MΩ	Max. Voltage	Operating Temperature Range	Safety Approvals	
	R ₂₅	Ts	V _{max}	T _L ~T _U	UL/cUL	TUV
	(KΩ)	(°C)	(V _{DC})	(°C)		
TPM1S102P095R	1	95±5	32	-25 ~ +110		
TPM1S102P105R		105±5		-25 ~ +120		
TPM1S102P115R		115±5		-25 ~ +130		

PTC Thermistor : TPM-S Series

SMD PTC Thermistor for Temperature Sensing



0603 Series

Part No.	Zero Power Resistance at 25°C	Sensing Temperature at 4.7MΩ	Max. Voltage	Operating Temperature Range	Safety Approvals	
	R ₂₅	T _s	V _{max}	T _L ~T _U	UL/cUL	TUV
	(KΩ)	(°C)	(V _{DC})	(°C)		
TPM1S103P075R	10	75±5	32	-25 ~ +90		
TPM1S103P080R		80±5		-25 ~ +95	√	
TPM1S103P110R		110±5		-25 ~ +125	√	√
TPM1S103P120R		120±5		-25 ~ +135	√	√
TPM1S103P130R		130±5		-25 ~ +145	√	√
TPM1S473P130R	47	130±5		-25 ~ +145	√	√

0805 Series

Part No.	Zero Power Resistance at 25°C	Sensing Temperature at 1KΩ	Max. Voltage	Operating Temperature Range	Safety Approvals	
	R ₂₅	T _s	V _{max}	T _L ~T _U	UL/cUL	TUV
	(Ω)	(°C)	(V _{DC})	(°C)		
TPM2S150N130R	15	130±7	32	-25 ~ +145		

Part No.	Zero Power Resistance at 25°C	Sensing Temperature at 1KΩ	Max. Voltage	Operating Temperature Range	Safety Approvals	
	R ₂₅	T _s	V _{max}	T _L ~T _U	UL/cUL	TUV
	(Ω)	(°C)	(V _{DC})	(°C)		
TPM2S101N110R	100	110±7	24	-25 ~ +125	√	
TPM2S101N115R		115±7		-25 ~ +130	√	
TPM2S101N130R		130±7		-25 ~ +145	√	

Part No.	Zero Power Resistance at 25°C	Sensing Temperature at 4.7 KΩ	Max. Voltage	Operating Temperature Range	Safety Approvals	
	R ₂₅	T _s	V _{max}	T _L ~T _U	UL/cUL	TUV
	(Ω)	(°C)	(V _{DC})	(°C)		
TPM2S471P065R	470	65±5	32	-25 ~ +80	√	√
TPM2S471P075R		75±5		-25 ~ +90	√	√
TPM2S471P085R		85±5		-25 ~ +100	√	√
TPM2S471P090R		90±5		-25 ~ +105		
TPM2S471P095R		95±5		-25 ~ +110	√	√

PTC Thermistor : TPM-S Series

SMD PTC Thermistor for Temperature Sensing



0805 Series

Part No.	Zero Power Resistance at 25°C	Sensing Temperature at 4.7 KΩ	Max. Voltage	Operating Temperature Range	Safety Approvals	
	R ₂₅	T _s	V _{max}	T _L ~T _U	UL/cUL	TUV
	(Ω)	(°C)	(V _{DC})	(°C)		
TPM2S471P100R	470	100±5	32	-25 ~ +115		
TPM2S471P105R		105±5		-25 ~ +120	√	√
TPM2S471P115R		115±5		-25 ~ +130	√	√
TPM2S471P120R		120±5		-25 ~ +135		
TPM2S471P125R		125±5		-25 ~ +140	√	√
TPM2S471P135R		135±5		-25 ~ +150	√	√

Part No.	Zero Power Resistance at 25°C	Sensing Temperature	Resistance			Max. Voltage	Operating Temperature Range	Safety Approvals	
	R ₂₅	T _s	T _s -5°C	T _s +5°C	T _s +15°C	V _{max}	T _L ~T _U	UL/cUL	TUV
	(Ω)	(°C)	(KΩ)	(KΩ)	(KΩ)	(V _{DC})	(°C)		
TPM2S681P070R	680	70	≤ 5.5	≥ 13.3	≥ 40	32	-40 ~ +125		
TPM2S681P080R		80					-40 ~ +125		
TPM2S681P090R		90					-40 ~ +125	√	
TPM2S681P095R		95					-40 ~ +125		
TPM2S681P100R		100					-40 ~ +125	√	
TPM2S681P105R		105					-40 ~ +130		
TPM2S681P110R		110					-40 ~ +135	√	
TPM2S681P115R		115					-40 ~ +140		
TPM2S681P120R		120					-40 ~ +145		
TPM2S681P130R		130					-40 ~ +150		

Part No.	Zero Power Resistance at 25°C	Sensing Temperature at 4.7 KΩ	Max. Voltage	Operating Temperature Range	Safety Approvals	
	R ₂₅	T _s	V _{max}	T _L ~T _U	UL/cUL	TUV
	(KΩ)	(°C)	(V _{DC})	(°C)		
TPM2S103P110R	10	110±5	32	-25 ~ +125		
TPM2S103P130R		130±5		-25 ~ +145	√	

PTC Thermistor : TPM-S Series

SMD PTC Thermistor for Temperature Sensing



Resistance-Temperature Characteristics (Typical)

SMD 0402 R25=470Ω
TPM0S471PXXXR

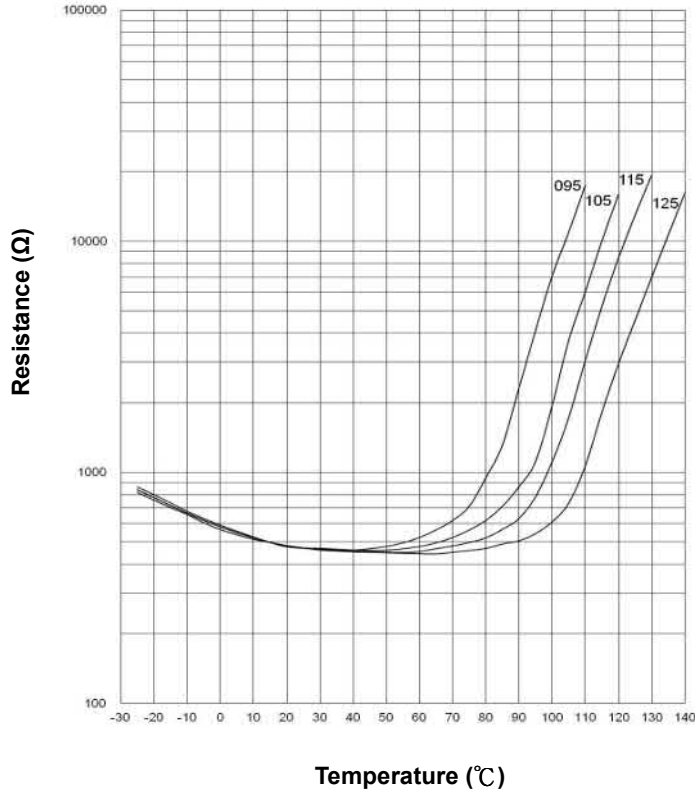

SMD 0402
R25=470Ω TPM0S471P115RT
R25=540Ω TPM0S541N115RT

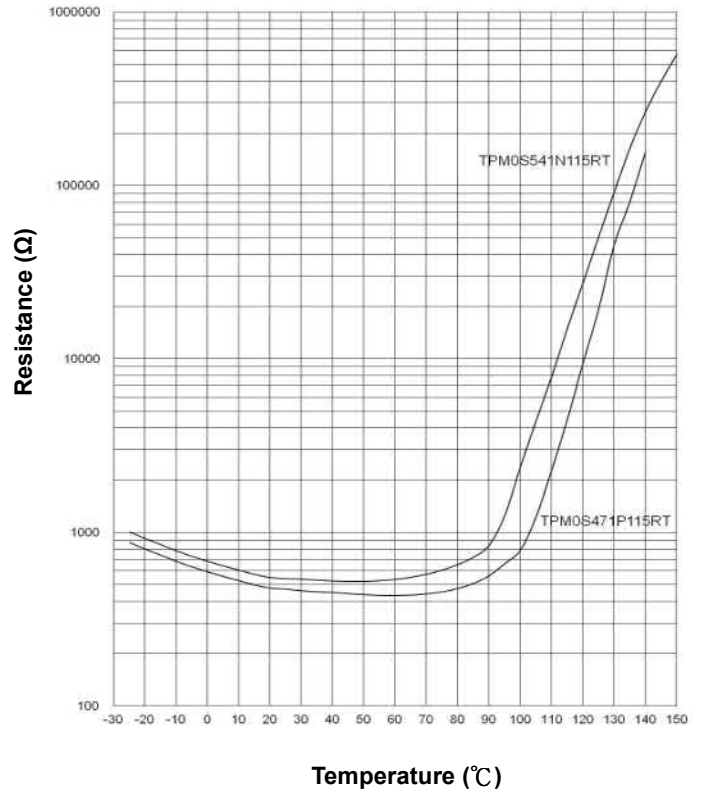

SMD 0402 R25=1KΩ
TPM0S102PXXXR

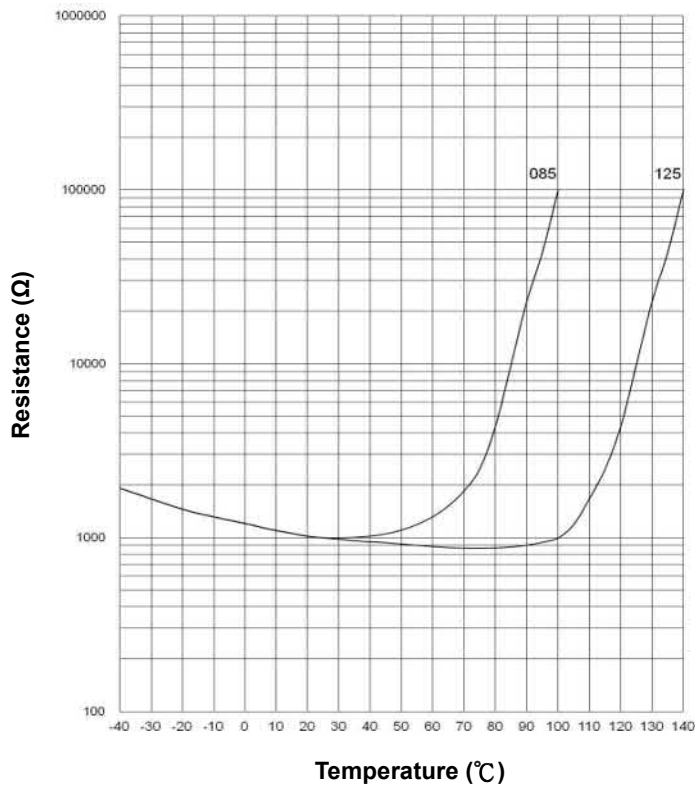

SMD 0402 R25=1KΩ
TPM0S102PXXXRS (RT)

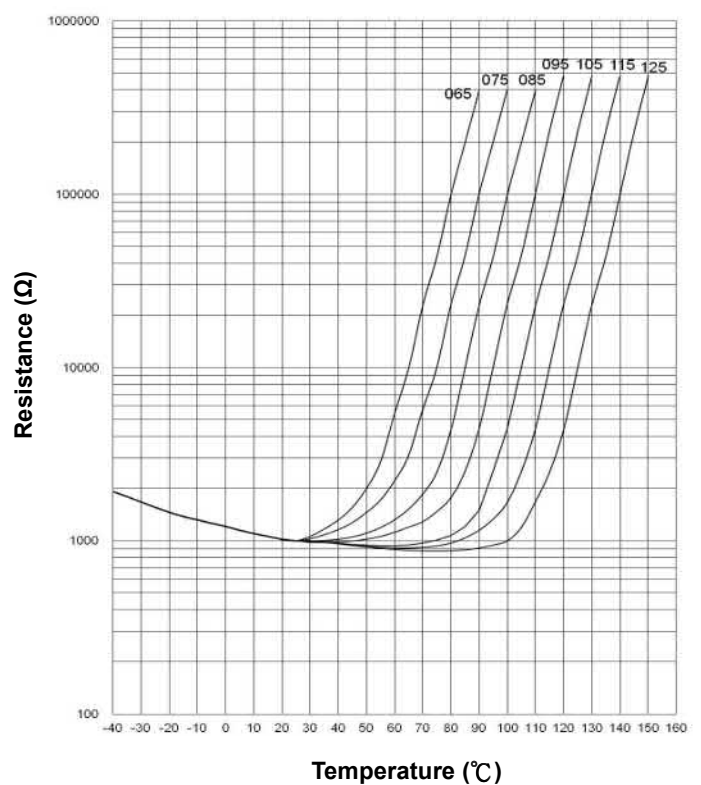

PTC Thermistor : TPM-S Series

SMD PTC Thermistor for Temperature Sensing



Resistance-Temperature Characteristics (Typical)

SMD 0402 R25=10KΩ
TPM0S103PXXR

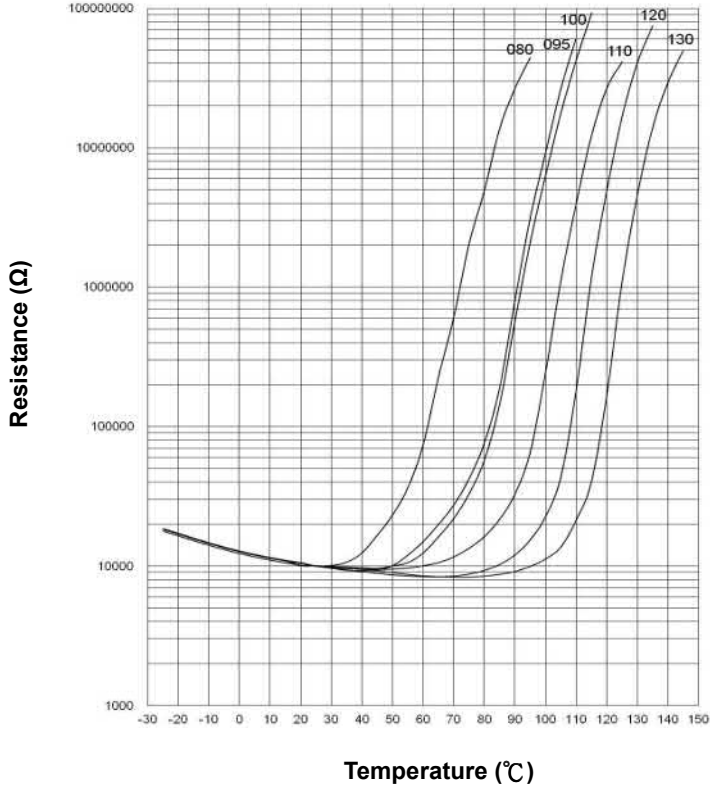

SMD 0402 R25=47KΩ
TPM0S473P130R

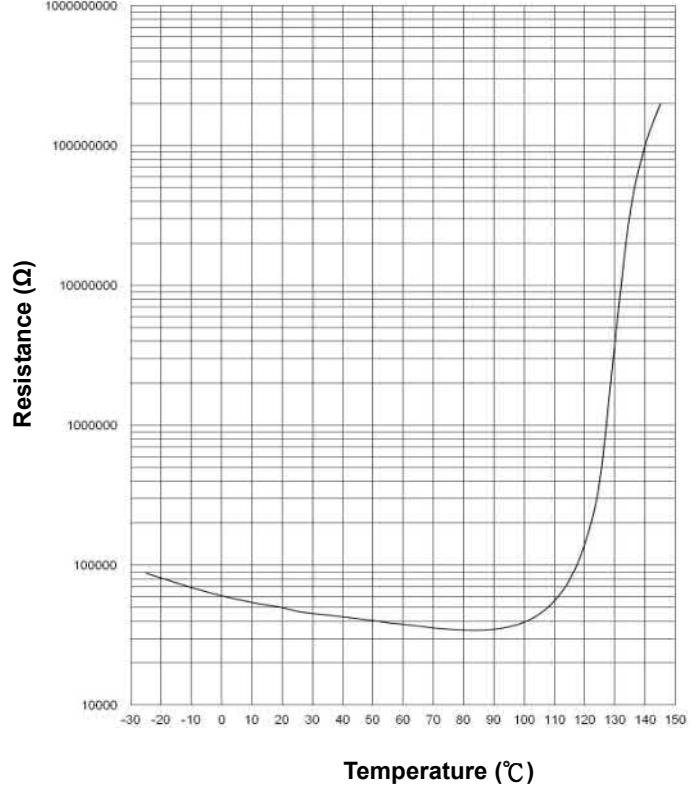

SMD 0603 R25=100Ω
TPM1S101N115R & TPM1S101N130R

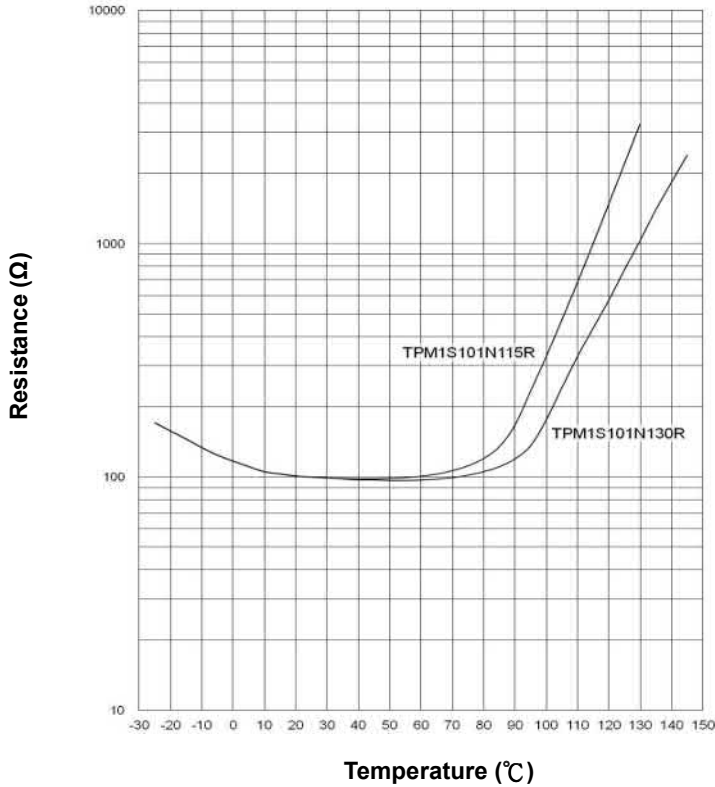

SMD 0603 R25=220Ω
TPM1S221N090R & TPM1S221N105R

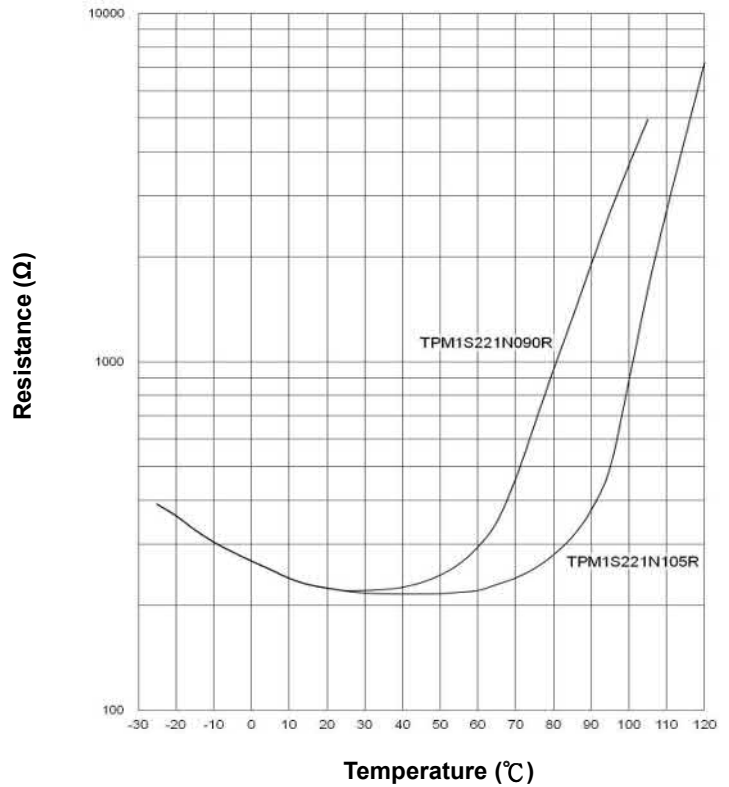

PTC Thermistor : TPM-S Series

SMD PTC Thermistor for Temperature Sensing



Resistance-Temperature Characteristics (Typical)

SMD 0603 R25=470Ω
TPM1S471PXXXR

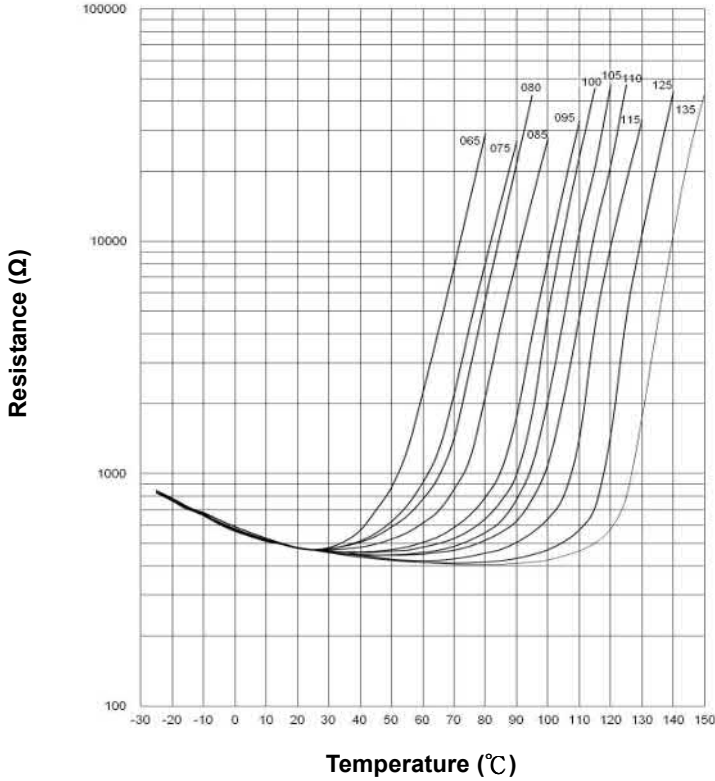

SMD 0603 R25=470Ω
TPM1S471PXXXRT

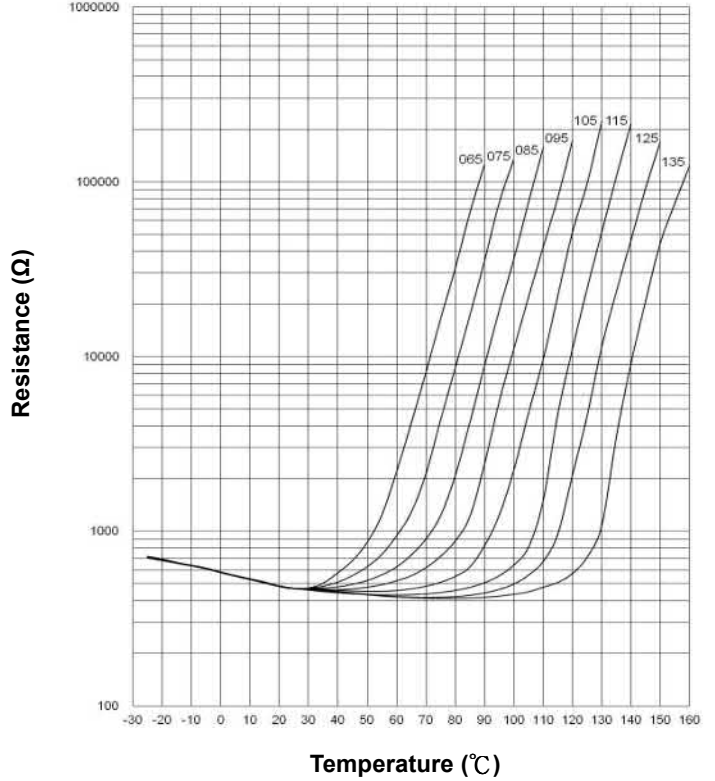

SMD 0603 R25=1KΩ
TPM1S102PXXXR

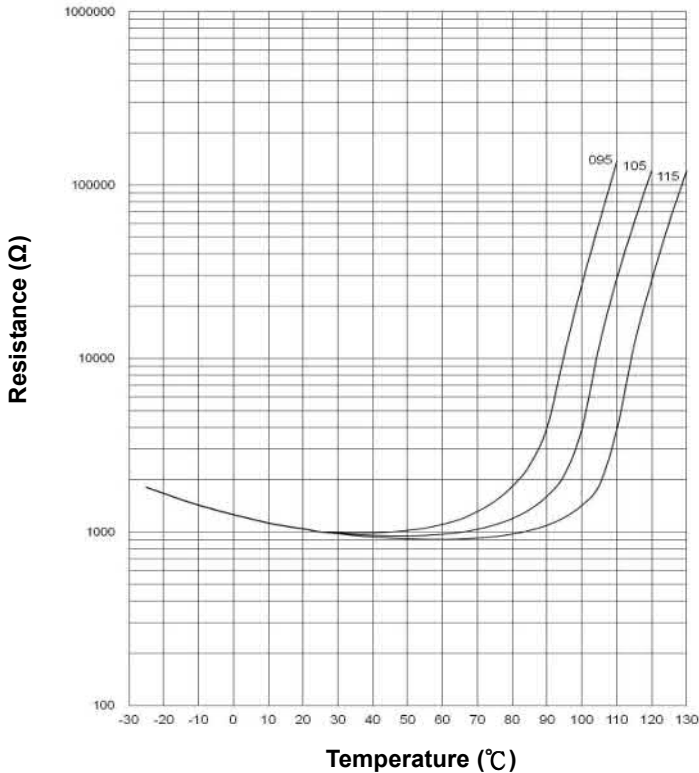

SMD 0603 R25=10KΩ
TPM1S103PXXXR

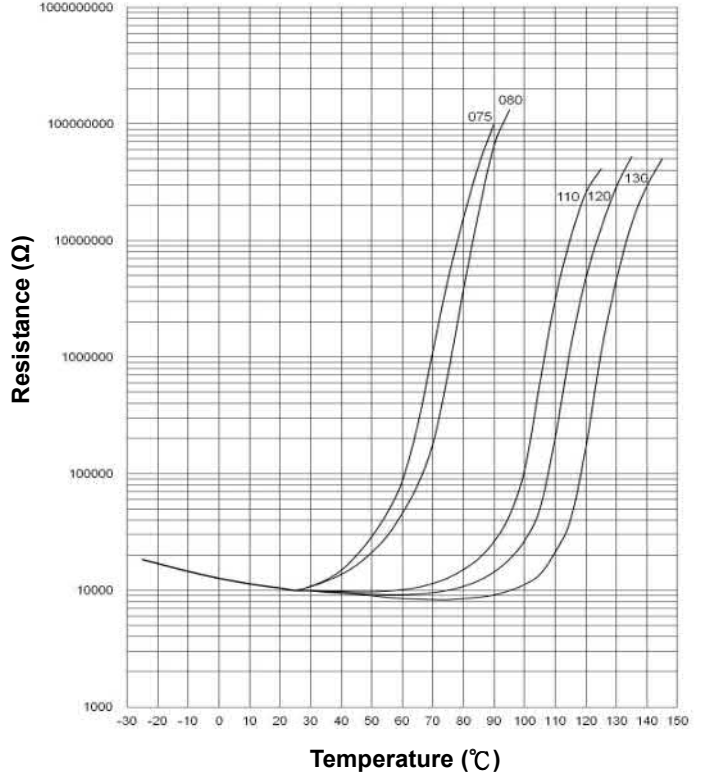

PTC Thermistor : TPM-S Series

SMD PTC Thermistor for Temperature Sensing



Resistance-Temperature Characteristics (Typical)

SMD 0603 R25=47K Ω
TPM1S473P130R

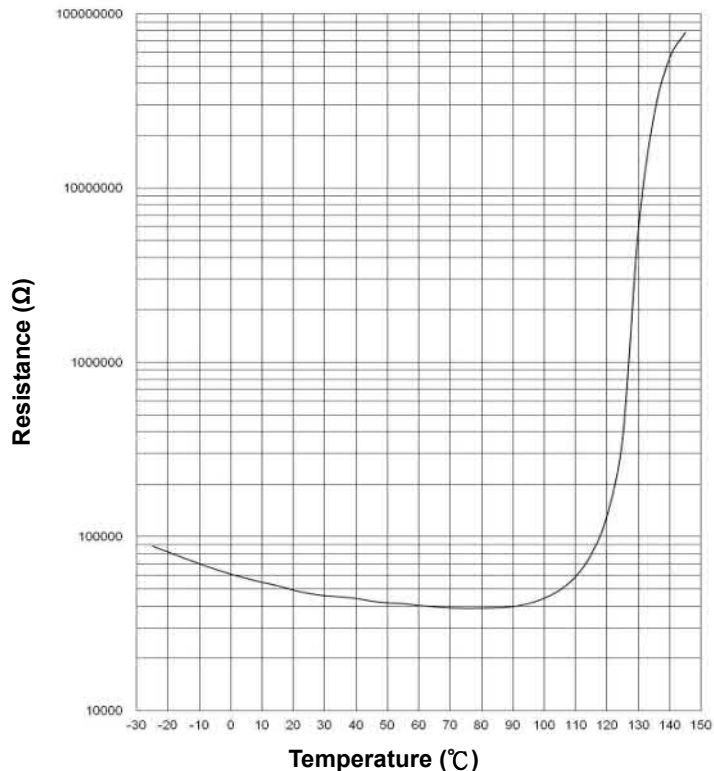

SMD 0805 R25=15 Ω
TPM2S150N130R

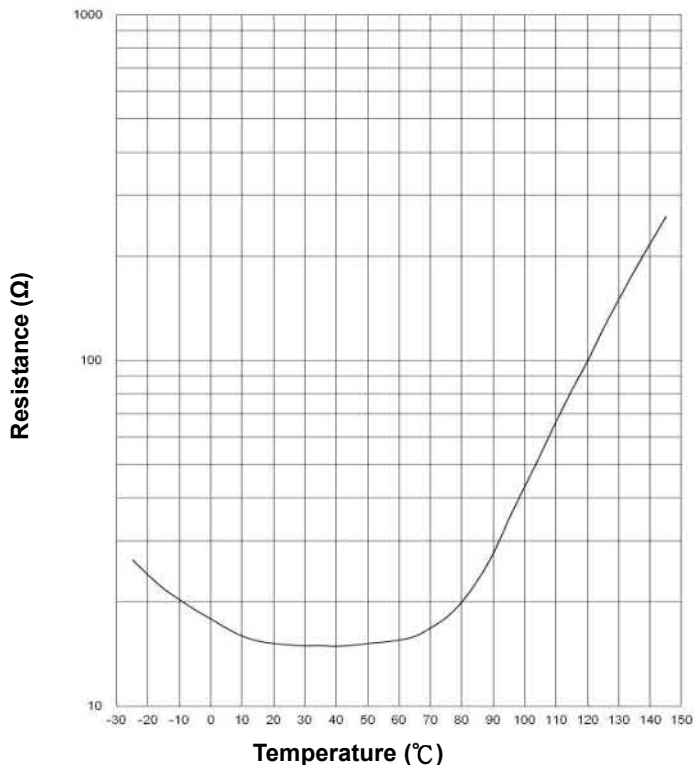

SMD 0805 R25=100 Ω
TPM2S101NXXXXR

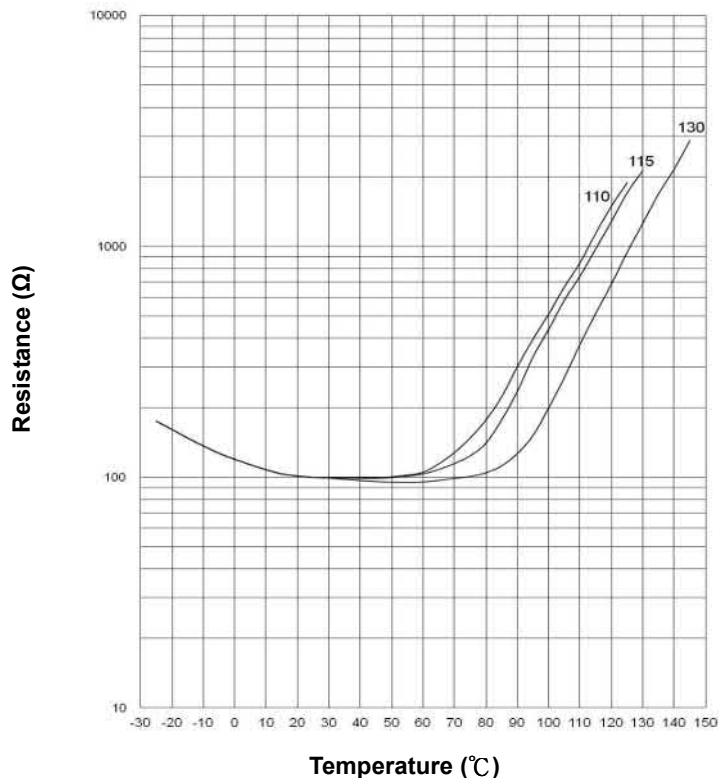

SMD 0805 R25=470 Ω
TPM2S471PXXXXR

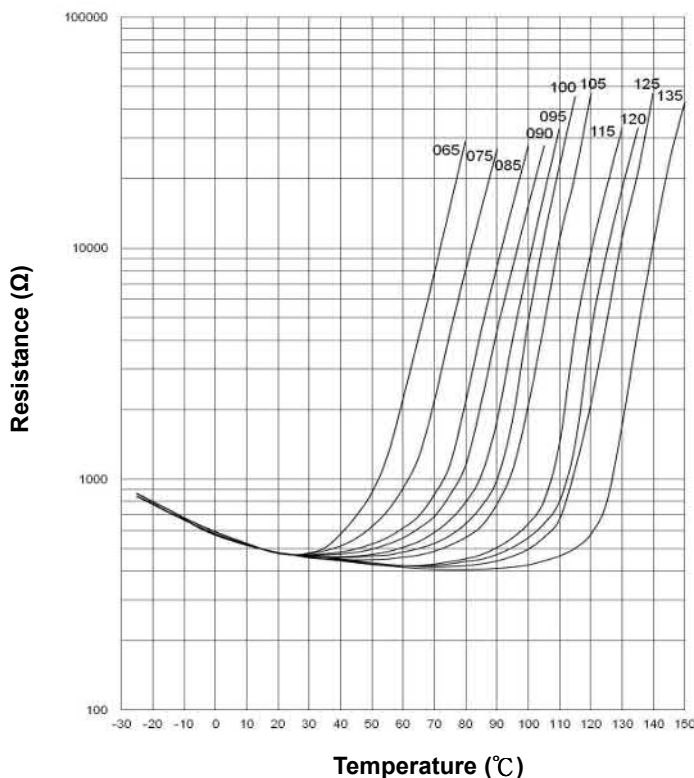

PTC Thermistor : TPM-S Series

SMD PTC Thermistor for Temperature Sensing



■ Resistance-Temperature Characteristics (Typical)

SMD 0805 R25=680Ω
TPM2S681PXXXR

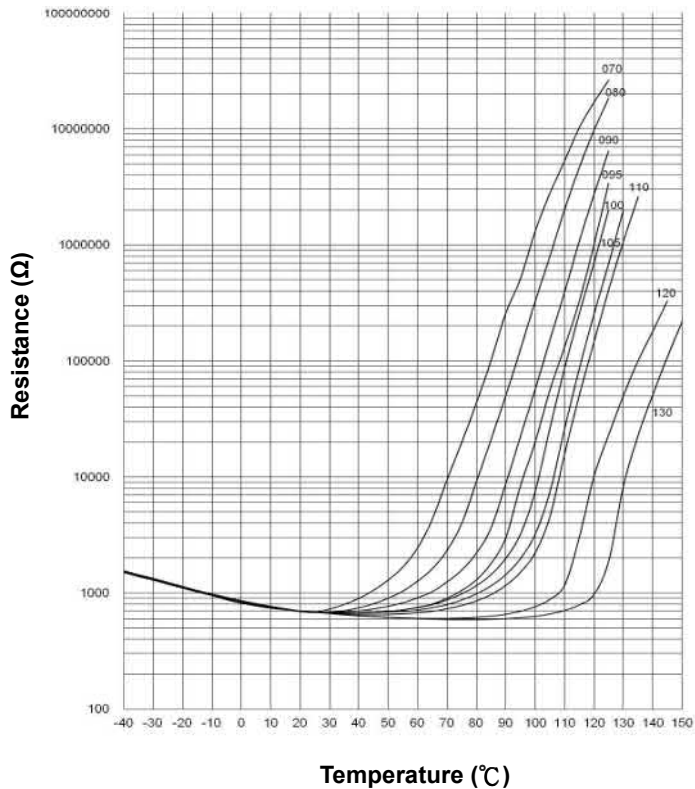

SMD 0805 R25=10KΩ
TPM2S103P110R & TPM2S103P130R

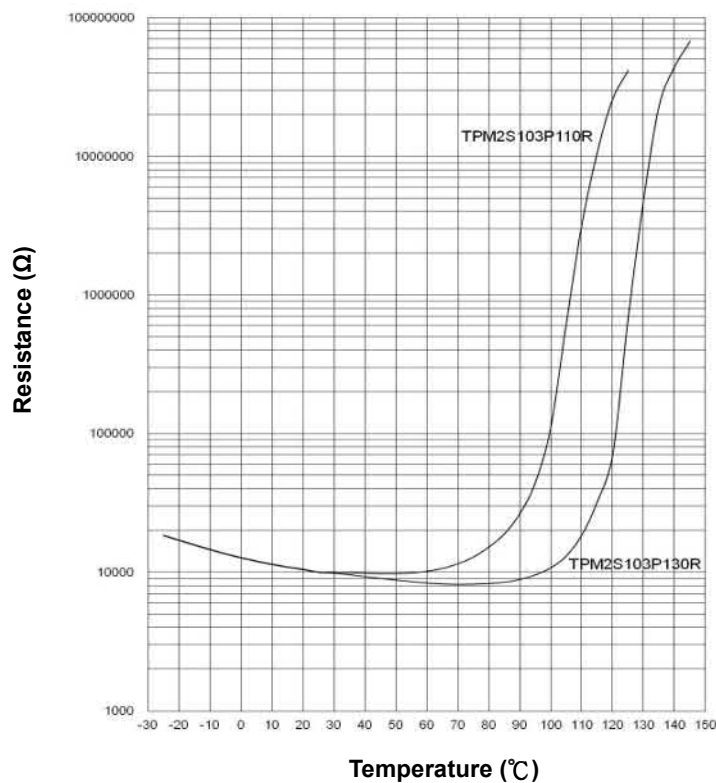

PTC Thermistor : TPM-S Series

SMD PTC Thermistor for Temperature Sensing



■ Typical Application Circuit

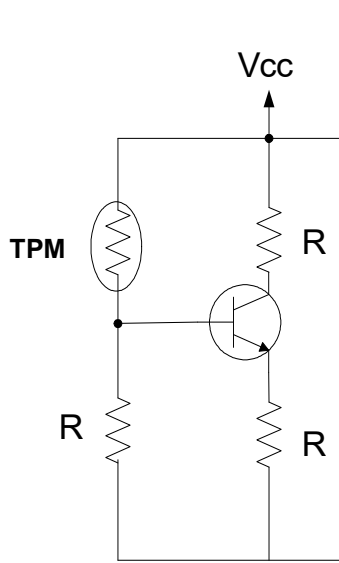

Fig 1. Overheat Protection

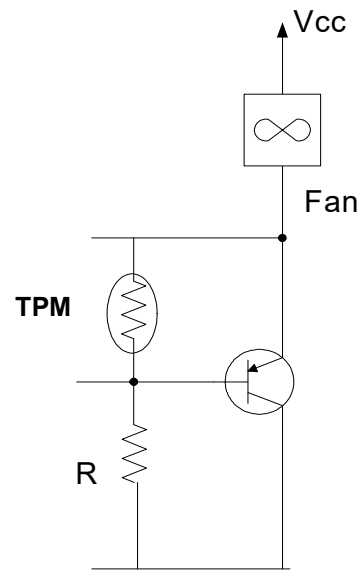

Fig 2. Temp. Sensing and Control

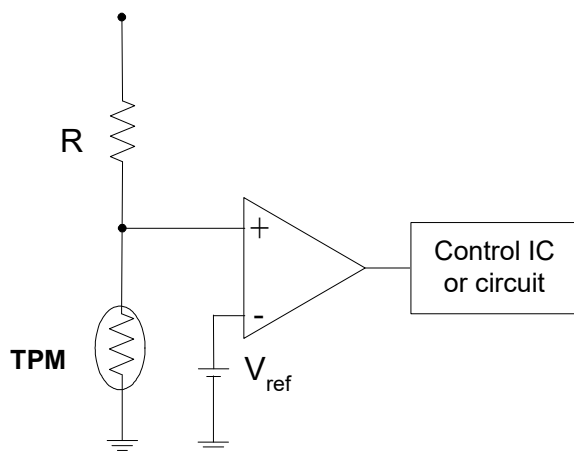

Fig 3. Comparator Circuit

PTC Thermistor : TPM-S Series

SMD PTC Thermistor for Temperature Sensing



■ Soldering Recommendation

● IR-Reflow Soldering Profile

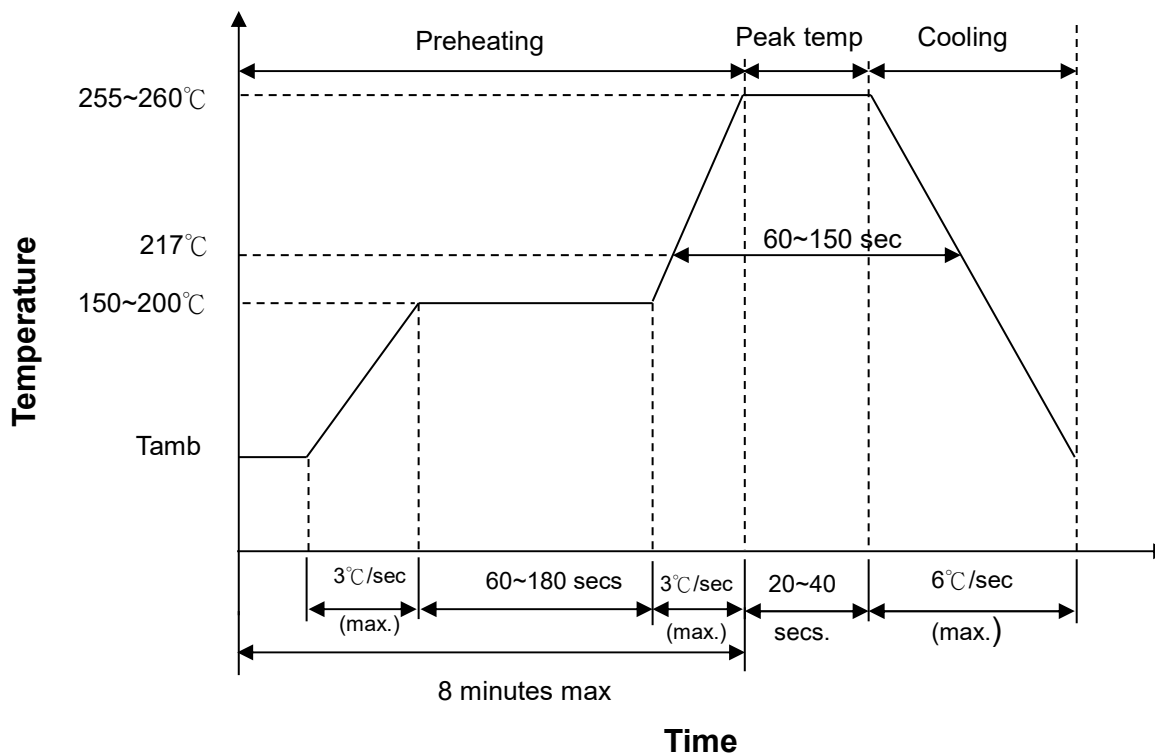

● Recommended Reworking Conditions with Soldering Iron

Item	Conditions
Temperature of Soldering Iron-tip	360°C (max.)
Soldering Time	3 sec (max.)
Diameter of Soldering Iron-tip	Φ3mm (max.)

Caution: Do not touch the component surface with soldering iron directly to prevent component damage.

PTC Thermistor : TPM-S Series

SMD PTC Thermistor for Temperature Sensing



■ Recommended Soldering Pad Dimensions

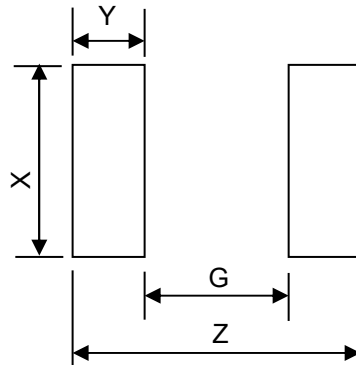

Size(EIA)	Z (mm)	G (mm)	X (mm)	Y (mm)
0402	1.4	0.4	0.5	0.5
0603	2.8	0.8	1.0	1.0
0805	3.4	1.0	1.4	1.2

PTC Thermistor : TPM-S Series

SMD PTC Thermistor for Temperature Sensing



■ Reliability (Single sensing temperature series)

Item	Standard	Test Conditions / Methods	Specifications															
Rapid Change of Temperature	IEC 60068-2-14	<p>The conditions shown below shall be repeated 5 cycles on PCB</p> <table border="1"> <thead> <tr> <th>Step</th> <th>Temperature (°C)</th> <th>Period (minutes)</th> </tr> </thead> <tbody> <tr> <td>1</td> <td>-25 ± 3</td> <td>30 ± 3</td> </tr> <tr> <td>2</td> <td>Room temperature</td> <td>≤3</td> </tr> <tr> <td>3</td> <td>150 ± 2</td> <td>30 ± 3</td> </tr> <tr> <td>4</td> <td>Room temperature</td> <td>≤3</td> </tr> </tbody> </table>	Step	Temperature (°C)	Period (minutes)	1	-25 ± 3	30 ± 3	2	Room temperature	≤3	3	150 ± 2	30 ± 3	4	Room temperature	≤3	<p>No visible damage $\Delta R_{25}/R_{25} \leq 20\%$ $(\Delta R_{25}/R_{25} \leq 30\% \text{ *1})$</p>
Step	Temperature (°C)	Period (minutes)																
1	-25 ± 3	30 ± 3																
2	Room temperature	≤3																
3	150 ± 2	30 ± 3																
4	Room temperature	≤3																
Damp Heat, Steady State	IEC 60068-2-78	40 ± 2°C, 90 ~ 95% RH , 1000± 24 hrs	<p>No visible damage $\Delta R_{25}/R_{25} \leq 20\%$ $(\Delta R_{25}/R_{25} \leq 30\% \text{ *1})$</p>															
Bending Strength	IEC-60068-2-21	<p>Warp 2mm Speed < 0.5mm/sec. Duration: 10 sec on PCB</p> 	<p>No visible damage $\Delta R_{25}/R_{25} \leq 10\%$</p>															
High Temp. Storage	IEC 60068-2-2	Tu. ± 2°C , 1000 ± 24 hrs	<p>No visible damage $\Delta R_{25}/R_{25} \leq 20\%$ $(\Delta R_{25}/R_{25} \leq 30\% \text{ *1})$</p>															
Low Temp. Storage	IEC 60068-2-1	<p>T_L ± 3°C , 1000 ± 24 hrs (-40. ± 3°C , 1000 ± 24 hrs *1)</p>	<p>No visible damage $\Delta R_{25}/R_{25} \leq 20\%$ $(\Delta R_{25}/R_{25} \leq 30\% \text{ *1})$</p>															
High Temp. Load	IEC 60738-1 7.24.3	85 ± 5°C Vmax. , 1000 ± 24 hrs	<p>No visible damage $\Delta R_{25}/R_{25} \leq 20\%$ $(\Delta R_{25}/R_{25} \leq 30\% \text{ *1})$</p>															
Climatic Sequence	IEC 60738-1 7.22	<p>a. Tu. x 16 hrs b. 1st cycle : 40 °C 95 %RH x 24 hrs c. T_L x 2 hrs d. 5 cycles : 40°C 95% RH x 24 hrs / Cycle</p>	<p>No visible damage $\Delta R_{25}/R_{25} \leq 20\%$ $(\Delta R_{25}/R_{25} \leq 30\% \text{ *1})$</p>															
Solderability	IEC 60068-2-58	245 ± 5°C, 3 ± 0.3 sec	At least 95% of terminal electrode is covered by new solder															
Resistance to Soldering Heat	IEC 60068-2-58	<p>8.1.2.2 Solder reflow method Preheating: 150~180°C, 60~120 secs Peak temp.: 245~255°C, ≤20 secs.(reflow)</p>	<p>No visible damage $\Delta R_{25}/R_{25} \leq 20\%$ $(\Delta R_{25}/R_{25} \leq 30\% \text{ *1})$</p>															

NOTE: *1 : Apply to TPM0S103*; TPM0S473*; TPM1S103*; TPM1S473; TPM2S103* only

PTC Thermistor : TPM-S Series

SMD PTC Thermistor for Temperature Sensing

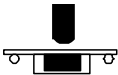

■ Reliability (Dual sensing temperature series)

Item	Standard	Test Conditions / Methods	Specifications															
Rapid Change of Temperature	IEC 60068-2-14	<p>The conditions shown below shall be repeated 5 cycles on PCB</p> <table border="1"> <thead> <tr> <th>Step</th> <th>Temperature (°C)</th> <th>Period (minutes)</th> </tr> </thead> <tbody> <tr> <td>1</td> <td>-25 ± 3</td> <td>30 ± 3</td> </tr> <tr> <td>2</td> <td>Room temperature</td> <td>≤3</td> </tr> <tr> <td>3</td> <td>150 ± 2</td> <td>30 ± 3</td> </tr> <tr> <td>4</td> <td>Room temperature</td> <td>≤3</td> </tr> </tbody> </table>	Step	Temperature (°C)	Period (minutes)	1	-25 ± 3	30 ± 3	2	Room temperature	≤3	3	150 ± 2	30 ± 3	4	Room temperature	≤3	<p>No visible damage Δ R₂₅/R₂₅ ≤ 20 %</p>
Step	Temperature (°C)	Period (minutes)																
1	-25 ± 3	30 ± 3																
2	Room temperature	≤3																
3	150 ± 2	30 ± 3																
4	Room temperature	≤3																
Damp Heat, Steady State	IEC 60068-2-78	40 ± 2°C, 90 ~ 95% RH , 1000± 24 hrs (85 ± 3°C, 80 ~ 85% RH , 1000± 24 hrs *1)	<p>No visible damage Δ R₂₅/R₂₅ ≤ 20 %</p>															
Bending Strength	IEC-60068-2-21	<p>Warp 2mm Speed < 0.5mm/sec. Duration: 10 sec on PCB.</p> 	<p>No visible damage Δ R₂₅/R₂₅ ≤ 10 %</p>															
High Temp. Storage	IEC 60068-2-2	Tu ± 2°C , 1000 ± 24 hrs (150.± 2°C , 1000 ± 24 hrs *1)	<p>No visible damage Δ R₂₅/R₂₅ ≤ 20 %</p>															
High Temp. Load	IEC 60738-1 7.24.3	85 ± 5°C Vmax. , 1000 ± 24 hrs	<p>No visible damage Δ R₂₅/R₂₅ ≤ 20 %</p>															
Climatic Sequence	IEC 60738-1 7.22	<p>a. Tu. x 16 hrs b. 1st cycle : 40 °C 95 %RH x 24 hrs c. TL x 2 hrs d. 5 cycles : 40°C 95% RH x 24 hrs / Cycle</p>	<p>No visible damage Δ R₂₅/R₂₅ ≤ 20 %</p>															
Low Temp. Storage	IEC 60068-2-1	T _L ± 3°C, 1000 ± 24 hrs (-40 ± 3°C, 1000 ± 24 hrs *1)	<p>No visible damage Δ R₂₅/R₂₅ ≤ 20 %</p>															
Solderability	IEC 60068-2-58	245 ± 5°C, 3 ± 0.3 sec	At least 95% of terminal electrode is covered by new solder															
Resistance to Soldering Heat	IEC 60068-2-58	8.1.2.2 Solder reflow method Preheating:150~180°C,60~120 secs Peak temp.:245~255°C,≤20 secs.(reflow)	<p>No visible damage Δ R₂₅/R₂₅ ≤ 20 %</p>															

NOTE:*1 : Apply to TPM0S102* only

PTC Thermistor : TPM-S Series

SMD PTC Thermistor for Temperature Sensing



■ Packaging

● Taping Specification (0402 type)

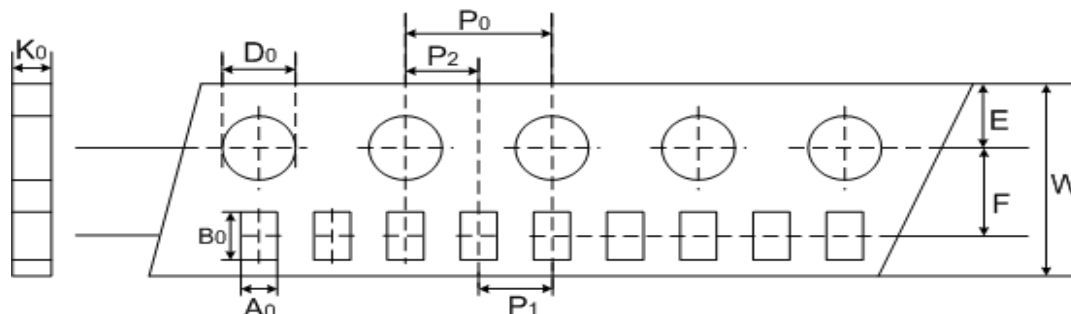

(Unit: mm)

Index Size	A ₀	B ₀	W	E	F	P ₁	P ₂	P ₀	D ₀	K ₀
0402	±0.05	±0.12	±0.2	±0.1	±0.05	±0.1	±0.05	±0.1	±0.1	±0.1

● Taping Specification (0603 & 0805 type)

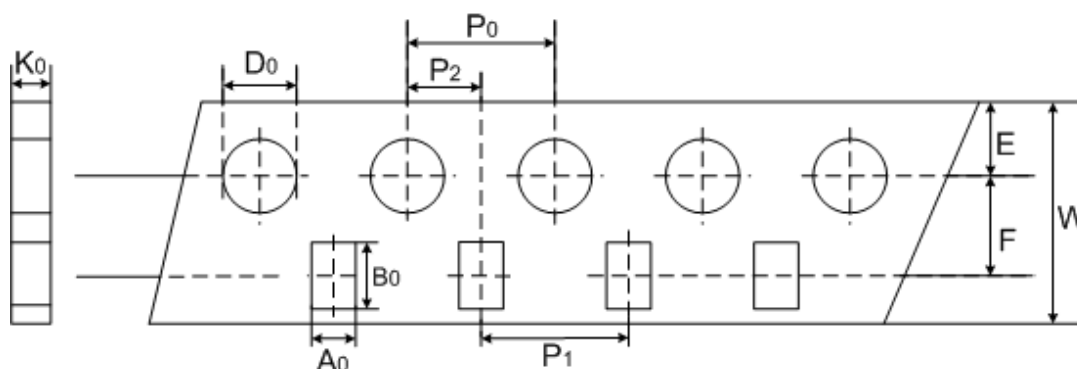

(Unit: mm)

Index Size	A ₀	B ₀	W	E	F	P ₁	P ₂	P ₀	D ₀	K ₀
0603	±0.2	±0.2	±0.2	±0.1	±0.05	±0.1	±0.05	±0.1	±0.1	±0.1
0805	1.5	2.3	8	1.75	3.5	4	2	4	1.55	1.0

PTC Thermistor : TPM-S Series

SMD PTC Thermistor for Temperature Sensing



Quantity

● 7" Reel

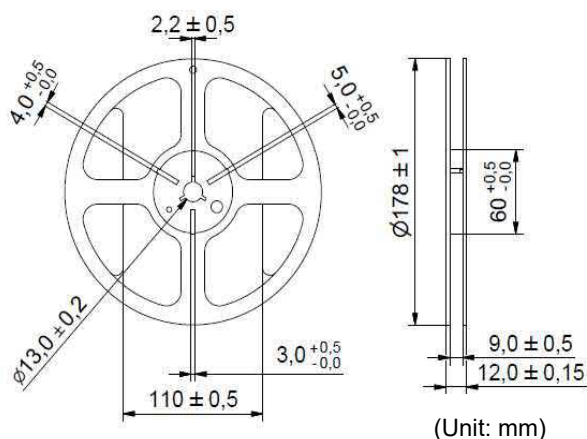

Size (EIA)	Quantity (pcs/reel)
0402	10,000
0603	4,000
0805	3,500

● 13" Reel

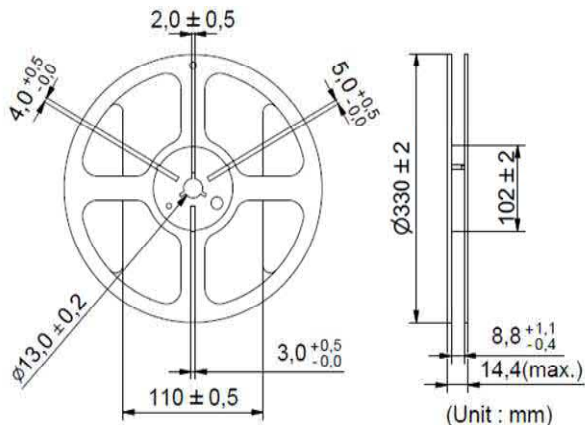

Size (EIA)	Quantity(pcs/reel)
0402	50,000
0603	16,000
0805	14,000

Warehouse Storage Conditions of Products

- Storage Conditions :
 1. Storage Temperature: $-10^{\circ}\text{C} \sim +40^{\circ}\text{C}$
 2. Relative Humidity: $\leq 75\% \text{RH}$
 3. Keep away from corrosive atmosphere and sunlight.
- Period of Storage : 1 year